



LOW NOISE, HIGH GAIN, GaAs FET TRANSIMPEDANCE AMPLIFIER

- ULTRA LOW NOISE - DOWN TO 1.0pA/√Hz
- HIGH GAIN - UP TO 1MV/A
- BANDWIDTH - FROM ≤ 250Hz TO 100MHz
- ACCEPTS CURRENT SOURCE INPUTS



DESCRIPTION:

The **312A Series** are ultra low noise, high gain, GaAs FET amplifiers designed for low level current source input applications in which high gain is required.

SPECIFICATIONS:

Input

Impedance Virtual ground, DC coupled
 Capacitance See graphs on reverse for performance vs. capacitance. Indicate value of input capacitance (Add - ___pF to part number.)

Output

Load ≥ 50Ω
 Swing 6V pk-pk AC coupled

Gain Error

< 2% at 2V pk-pk output

Polarity

Non-inverting

Power

+15VDC at 75mA typical

Temperature

-20° to +70°C

Connections

Input Pins
 Output BNC
 Power Filter feed-thru pins and ground lug
 Bias Decoupled Pin decoupled with 0.01μF, 1kV capacitor

Size

3.50" x 1.93" x 0.92"



Specifications subject to change without notice.

APPLICATIONS:

High Gain, High Sensitivity APD and PIN Photodiode Amplifier, Current to Voltage Converter

		MODEL NUMBER
		GAIN (1MV/A)
Bandwidth (1) ± 20%	≤ 250Hz - 10MHz	312A-2
	≤ 250Hz - 30MHz	312A-3
	≤ 250Hz - 100MHz	312A-4
Noise (1) ± 20%	Current Noise (Open circuit input)	1.0pA/√Hz

Typical Part Number: **312A-4-0pF =**

Bandwidth: ≤ 250Hz - 100MHz
 Gain: 1MV/A
 Noise: 1.0pA/√Hz
 Polarity: Non-Inverting
 Input Capacitance: 0pF

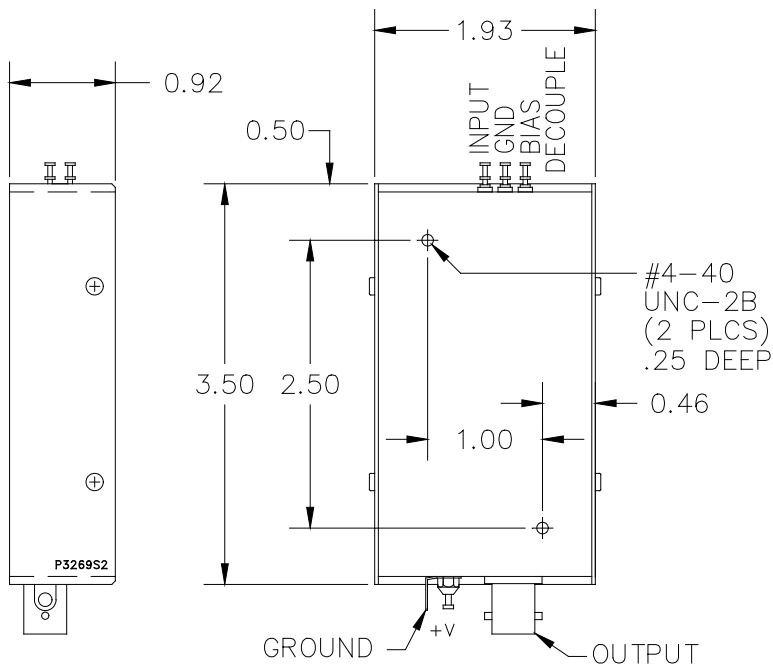

DIMENSIONS ARE IN INCHES

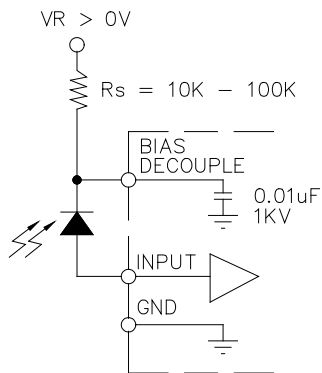
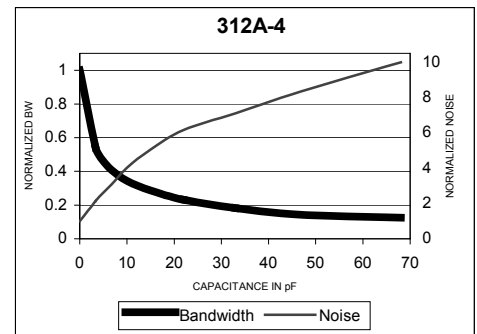
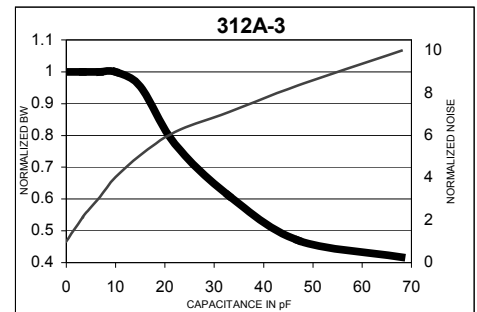
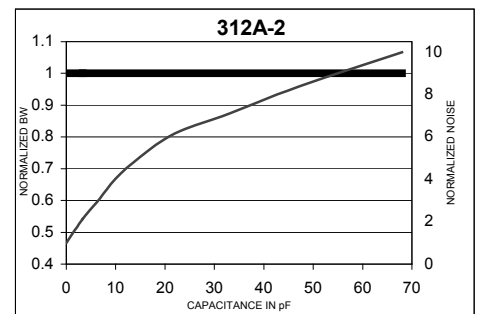

PHOTOCONDUCTIVE
MODE

TYPICAL PHOTODETECTOR APPLICATIONS