

HIGH PERFORMANCE HYBRID EYESAFE LASER RANGEFINDER RECEIVER

- SUPER HIGH SENSITIVITY DOWN TO 3nW
- OPTIMIZED FOR MULTIPLE TARGET RESOLUTION
- HYBRID CONSTRUCTION
- FAST RECOVERY FROM OVERLOAD
- THERMO-ELECTRICALLY COOLED DETECTOR
- TIME PROGRAMMED GAIN
- NOISE TRACKING THRESHOLD
- 28 PIN DIL HERMETIC PACKAGE
- NO NEGATIVE SUPPLY NEEDED
- NON-CRITICAL LASER PULSE TIMING

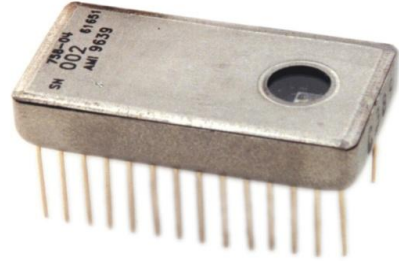

DESCRIPTION:

The **Model 758A** is a new generation of eyesafe laser rangefinder receivers optimized for ultra high sensitivity, excellent overload performance and exceptional ability to discriminate between two close targets. Pulsewidths from 1 to 40ns are processed over seven orders of magnitude dynamic range, and operation is possible from 1.0 to 1.6 μ m. The detector and critical pre-amplifier components are thermoelectrically-cooled to minimize noise using a built-in temperature sensor and controller. A choice of different sizes of InGaAs APD detectors is available to achieve optimum performance in different rangefinders. Time-programmed gain is triggered at T_O to eliminate false echoes at short ranges. Linear outputs are available for custom applications. Low-impedance output is provided for a range counter. The **Model 758A** is designed to meet the demanding requirements of military applications and offers the highest sensitivity of our family of rangefinder receivers. The small size and PCB mounting make it ideal for compact systems requiring high target fidelity and maximum performance.

SPECIFICATIONS:

Detectors/Sensitivity

(50% detection; 6ns pulse; 0.1% FAR; TEC set for 15°C)
Detector type: InGaAs APD

MODEL	DET \varnothing	TYP.	MAX.
758A-03	80 μ m	3nW	6nW
758A-04	200 μ m	6nW	9nW

At 1.06 μ m, multiply sensitivity value by 2.

Multiple Target Resolution

Small Signal	(50nW)	10 meters typical
Large Signal	(1mW)	20 meters typical

Dynamic Range 10⁷:1

Package 28 pin DIL-0.6" spacing, 0.1" pin spacing Ni plated, Kovar finish. Sapphire window, AR coated for <1% loss at 1.55 μ m.
Base heatsink required

Weight 0.5oz (14 gms)

Time Programmed Gain

Range Via external start signal, adjustable, programmable

Output

AC coupled, negative going pulse
5.9 to 6.5V no load
50 ohm source impedance
(see Application Note, page 7)

Power

+12VDC at 65mA typical
0.9V at 0.7A maximum for TEC
TEC cool down rate: 10°C/s
HV bias \geq 100V, 10 μ A
Built-in temperature-corrected shunt regulator for APD and TEC controller to drive an external power transistor.

Size

1.47" x 0.77" x 0.27" (0.3 cu. in.)
(37.3mm) x (19.6mm) x (6.9mm)
Pin length: 0.375" (9.5mm) typ.

Optical

>0.24" (6.1mm) dia. clear aperture.
Detector <0.040" (1mm) below
0.020" (0.5mm) thick window.

Temperature

Operating: -40°C to +71°C
Storage: -55°C to +85°C



See application notes for more information.

Specifications subject to change without notice.

U.S. Patent No. 6,650,404

APPLICATIONS:

Laser Rangefinder Systems, Target Detection Systems

"In the event this commodity will be transferred to a "foreign person" as defined in 22 CFR 120.16, either outside or within the United States, a validated US State Department license is required."

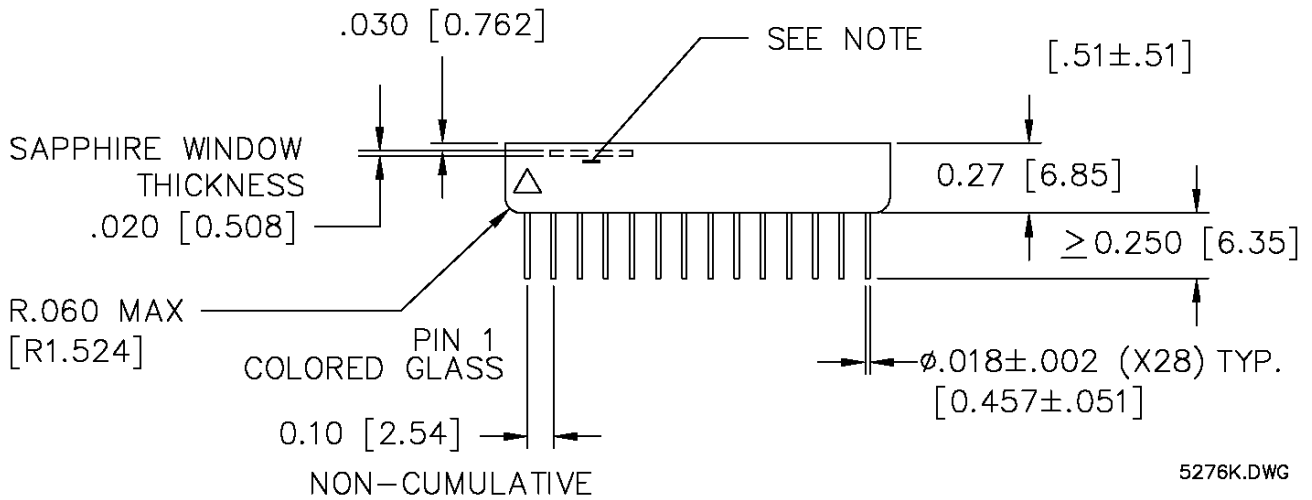
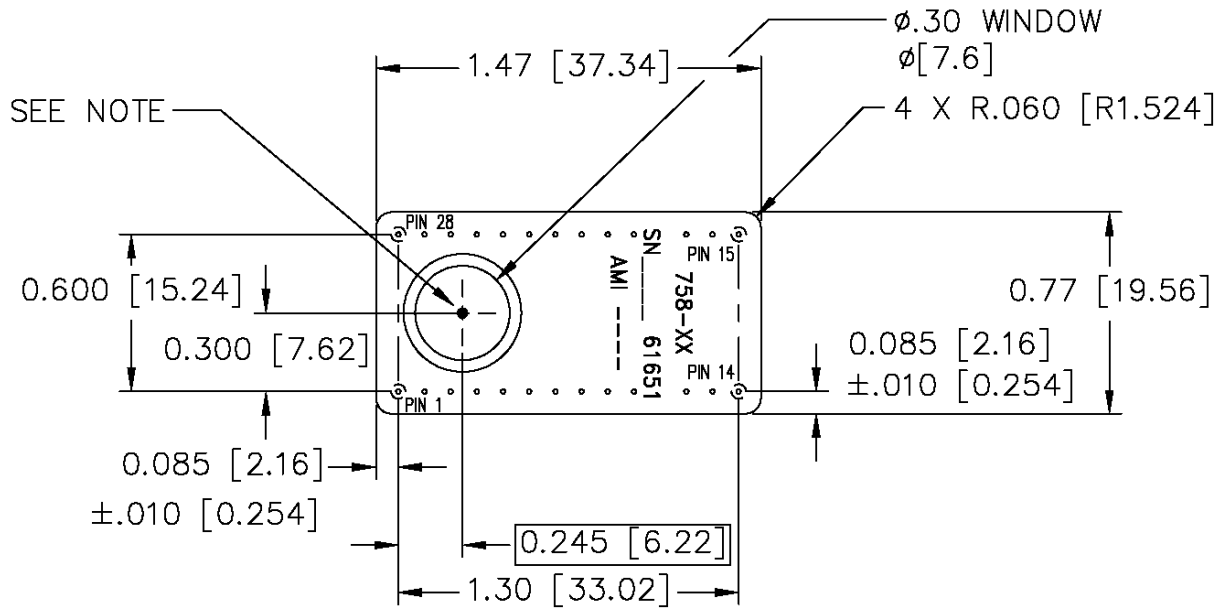

5276K.DWG

NOTE: FOR 758/758A/7580 SERIES

CLEARANCE TO CENTER TOP SURFACE OF DETECTOR IS 0.020 ± 0.020 ,
AND DETECTOR CENTER POINT IS LOCATED WITHIN 0.050 INCHES RADIALLY
WITH REFERENCE TO ITS NOMINAL POSITION.

DIMENSIONS AND PACKAGE DETAIL MODEL 758/758A/7580 SERIES